

Universal USB Serial Port

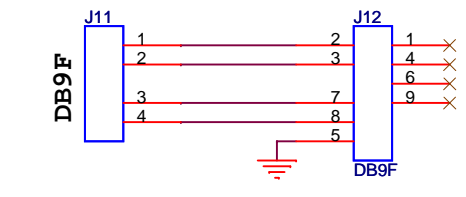

Select between USB powered and external power

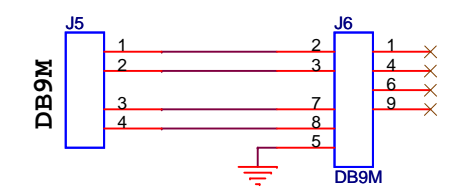
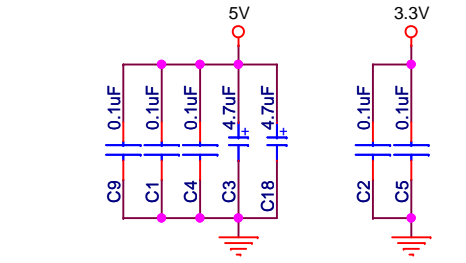
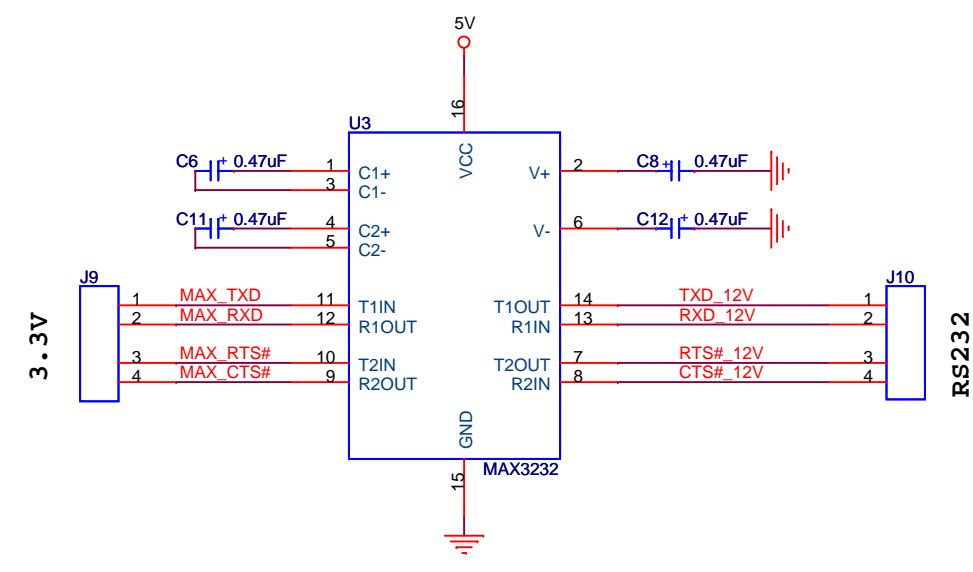
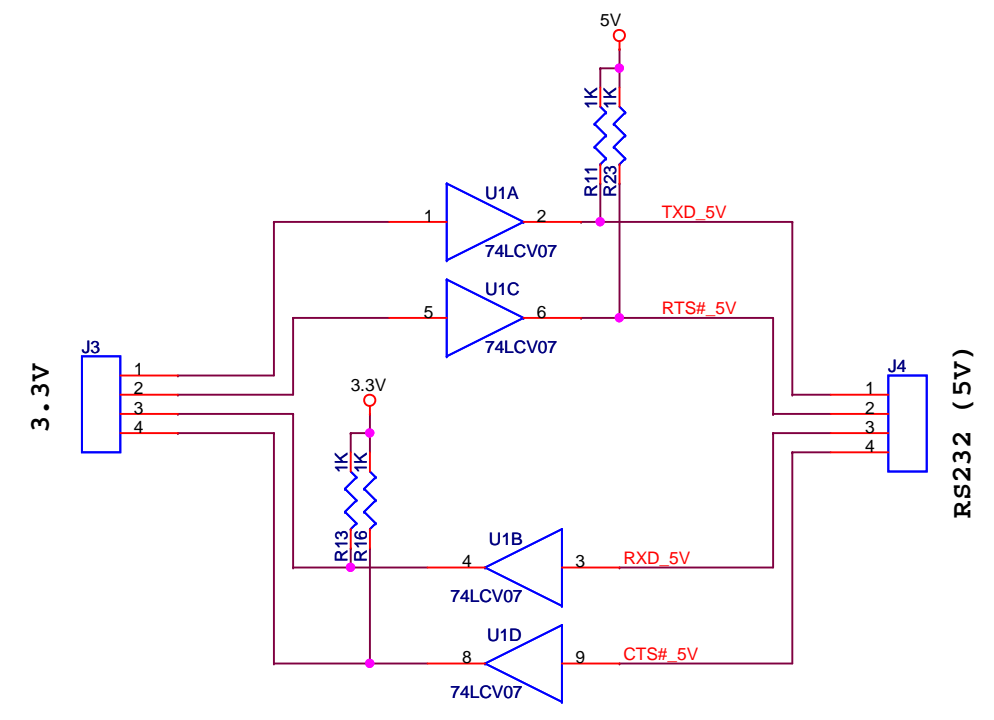
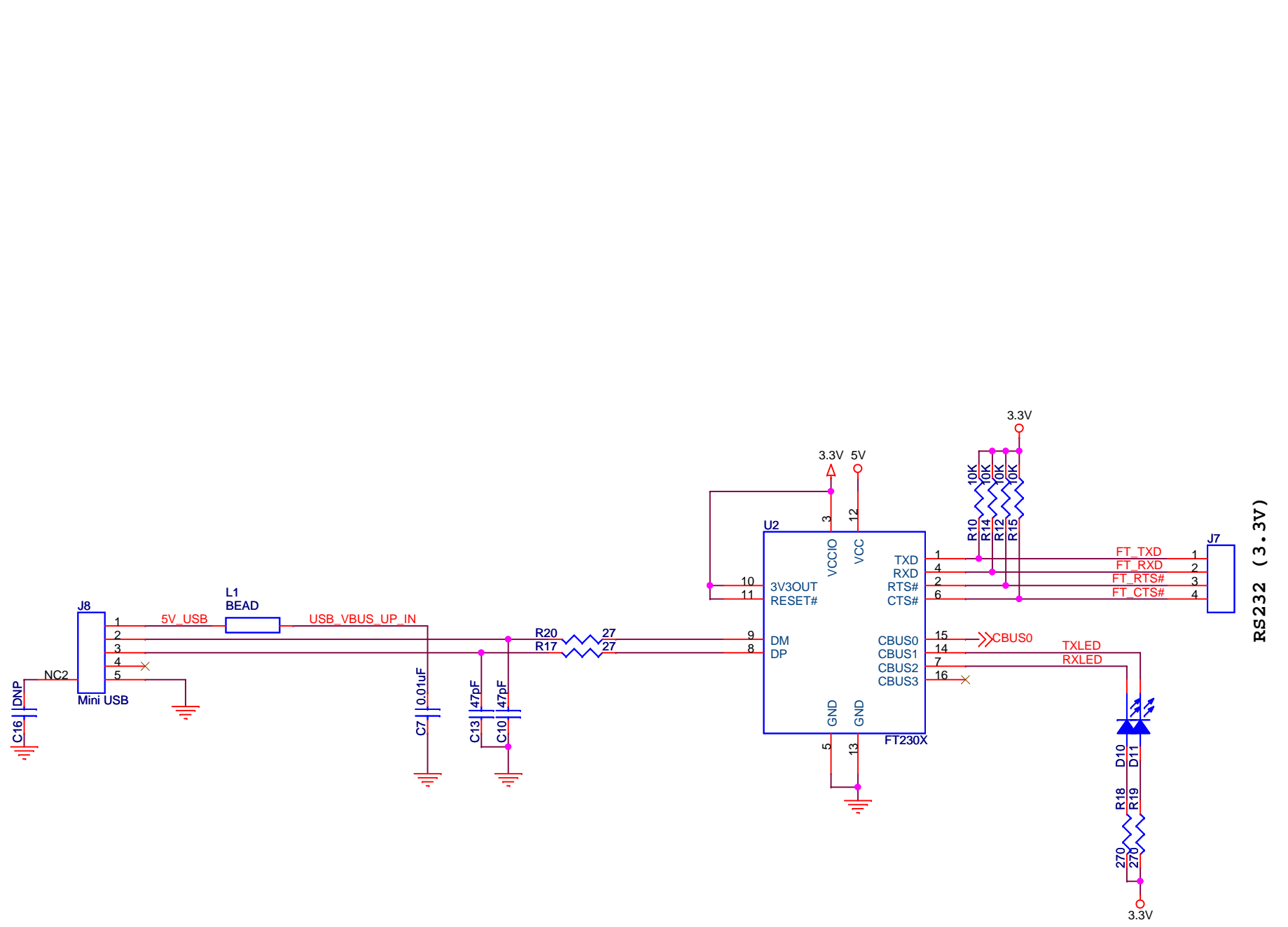
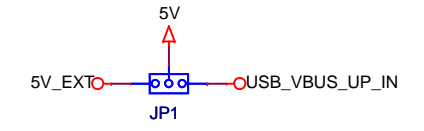

If USB not connected, supply 5V via test points

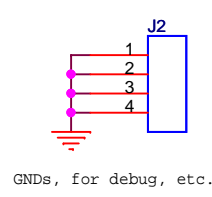
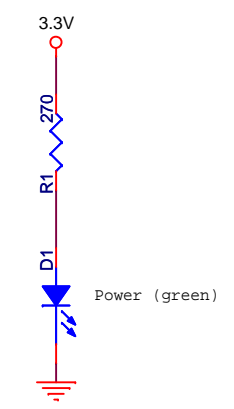
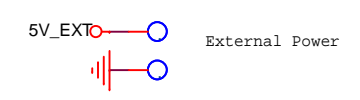

Title		Debug Buddy: Serial Port		Ross Wolin/Mystic Engineering	
Size	Document Number			Rev	1.4
C	<Doc>				
Date:	Monday, August 10, 2015	Sheet	0	of	2

Programmable level shifters
 VOUT is either 3.3V or 5V, inputs can be 3.3V or 5V

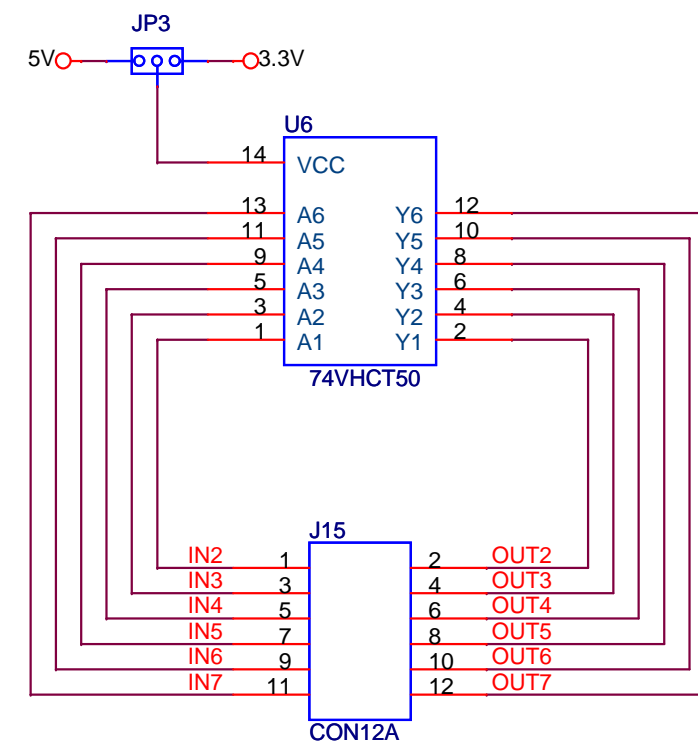
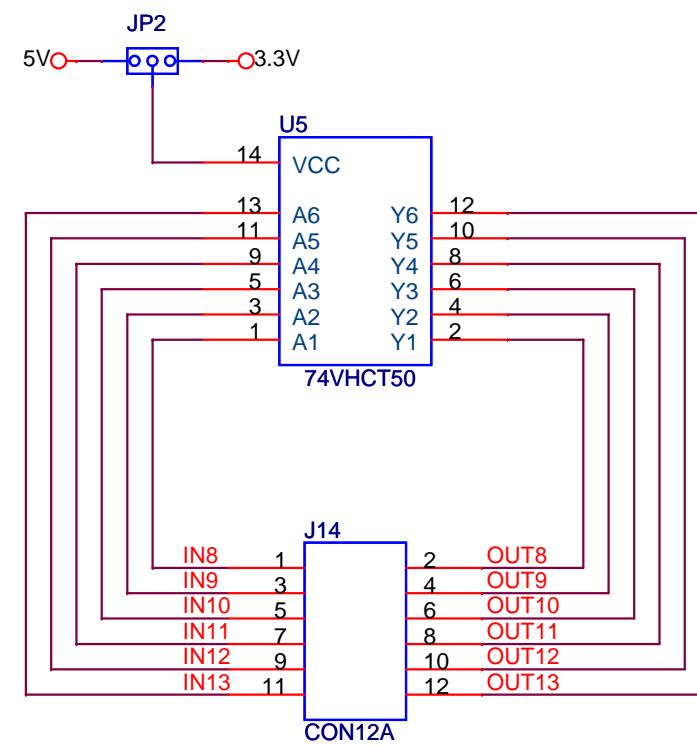
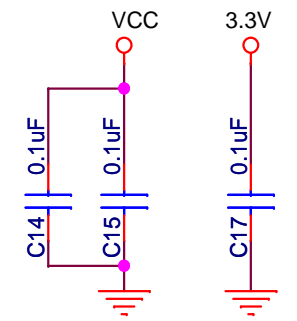

Clock outputs

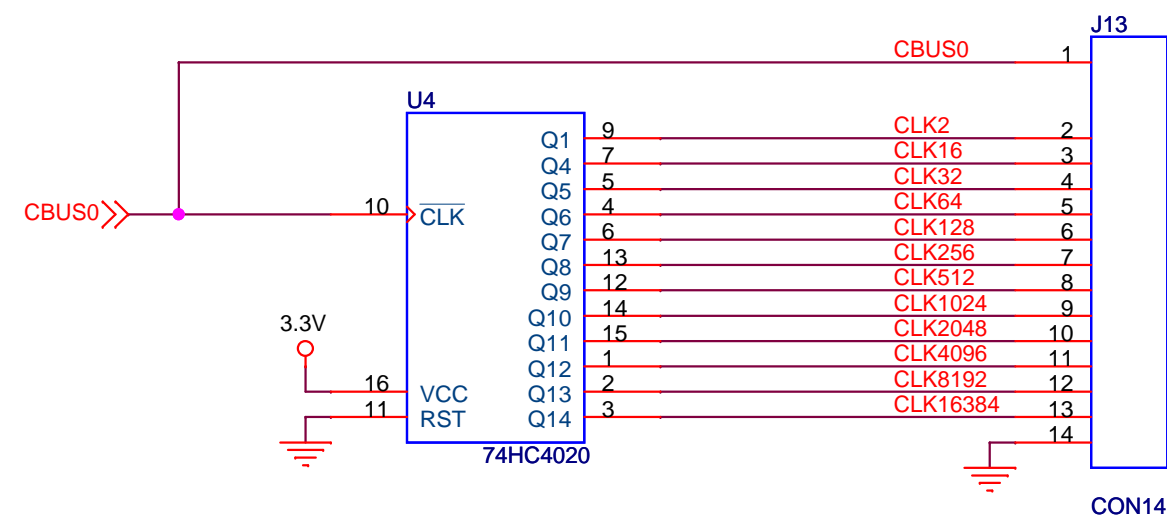

Debug LEDs, 3.3V or 5V okay

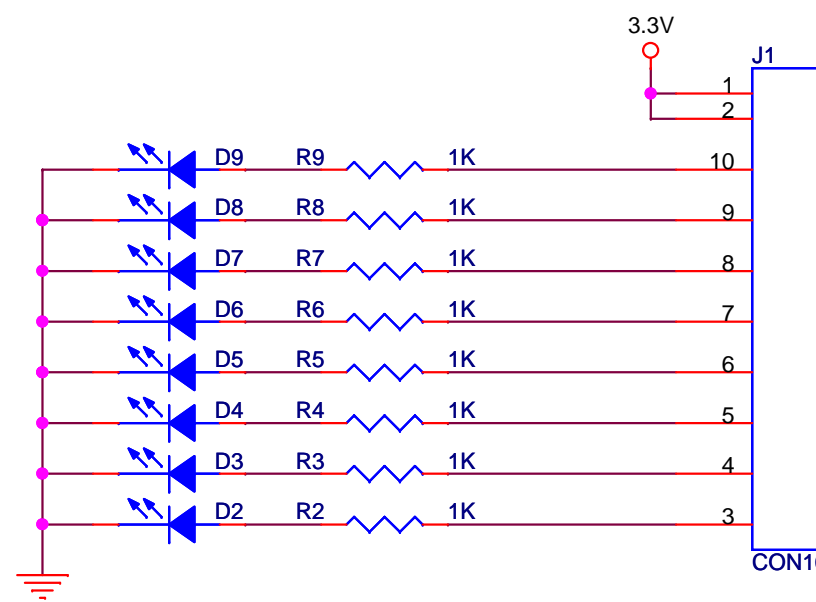

Title		Debug Buddy: Level Shifters, Clocks, LEDs		Ross Wolin/Mystic Engineering	
Size	Document Number			Rev	1.4
B	<Doc>				
Date:	Monday, August 10, 2015	Sheet	0	of	2